



Product card User manual

KP Strong Safe grade II and III with ECB-S certificate

KONSMETAL Export Department
export@konsmetal.pl

KONSMETAL Service:
phone: **+48 89 6253799** (Monday – Friday: 8-16)
e-mail: serwis@konsmetal.pl

Contents

Application	3
Certificates for storing	3
Important – read before operating the safe	3
Product description.....	4
Basic equipment.....	4
Basic equipment.....	4
Type of locks	5
Standard colours	5
Installation of separately lockable internal box	7
Installation of shelves	7
Operation - opening	7
Operation - closing	8
Use	9
Maintenance	9
Replacement of the electronic lock's battery	9
Adjustment of hinges	10
Most common problems and remedies	11
Contact details to the KONSMETAL Service.....	11

KP Strong Safe, grade II-III with ECB-S certificate



Application

KP Strong Safes provide a high degree of protection for storing valuables. They are designed to protect cash, checks, promissory notes, stocks and shares, documents and other important and valuable items. KP Strong Safes are usually used in banks, financial institutions and cashier rooms.

Certificates for storing

➤ Valuables in accordance with European Standard PN-EN 1143-1, grade II and III with ECB-S Certificate.

Warning! In order to keep the product's resistance grade safe or cabinet weighing up to 1 000 kg must be anchored to the ground according to the user manual.

Important – read before operating the safe

- ! Please read this user manual and follow its provisions.
- ! If the device is equipped with a combination or/and electronic lock ALWAYS remember to change a default code on its own, unknown to third parties, BEFORE using the device. Leaving default code is a threat to the security of deposited values.
- ! Changing the code and test of the new code in the combination or electronic lock MUST be done on the open door of the safe. By changing the code on closed door you run the risk of the need for their emergency opening.
- ! If the safe is equipped with a handle or knob to move the bolts, opening or closing the door should be done ONLY by holding the handle or knob to move the bolts. Opening or closing the safe door by pulling on the key, combination lock knob or electronic lock keypad can result in product damages, which are not subject to warranty.

KP Strong Safe, grade II-III with ECB-S certificate

- ! Before closing the safe door you MUST check if the bolts are maximally retracted. Extended bolts while closing the safe door can damage the paint coat at the place of bolts impact on the edge of the door opening. Such damage is not considered as a basis for warranty repair.
- ! At the end of this user manual you will find information how to conduct the most common problems.

Product description

- > Multi-layered structure of the body and door with a special filling; body armor thickness - 80mm, door thickness – 150 mm.
- > Elaborate bolting system: four horizontal bolts, two vertical bolts, one profiled fixed bolt protecting the door against opening after breaking the hinges.
- > Bolts diameter: 30 mm.
- > Bolts are moved using a rotary handle.
- > Indirect locking system to protect the lock during the attack on the bolts.
- > Reinforcements are placed within the door to prevent access to the bolts and acts as a fire protection system.
- > The system of protection against drilling bolts.
- > The system of protection of the lock against thermal attack.
- > The system of protection of the lock against drilling.
- > The protection of mechanism even after partial access to the interior of the safe.
- > Depending on the user's needs, Strong Safes can be equipped with a high-quality certified lock: key, combination or electronic. There is a possibility of installing any two locks in each device.
- > External hinges.
- > Door opening angle 195 degrees.
- > Doors are not flush with the body.
- > Strong Safes are painted with durable powder coatings.
- > 24-month warranty.

Basic equipment

- > Key lock grade A (product's grade: II), key lock grade B (product's grade III)
- > Shelves with a suspension height adjustment; maximum shelf load - 50kg;
- > Clips for shelf mounting.
- > Anchoring: perforations in the Strong Safe's bottom;
- > Operating manual for the installed combination locks (mechanical, electronic);
- > Operating and user's manual including a guarantee certificate.

Basic equipment

- > Third key to the key lock.
- > The possibility of installing locks in the following configurations: Key, Combination, Electronic, Key - Key, Combination - Key, Electronic - Key.
- > Key to change the combination of the installed mechanical combination locks.
- > Alarm system output - connection to a building's alarm system (on a lateral wall, on the hinge side).
- > Separately lockable internal boxes - additional protection.
- > Additional shelves.
- > Shock sensors - transmitting signals to the alarm system during a burglary attempt.
- > Bolt position sensor - transmitting signals about the door position to the alarm system.
- > Time delay and silent alarm to electronic lock.;
- > Expansion anchor for floor mounting .

KP Strong Safe, grade II-III with ECB-S certificate

Type of locks



key

combination

electronic

Standard colors

- Light grey RAL 7035.
- Light grey RAL 9002.
- Black RAL 9005.

* Any color from the RAL palette to order (powder coated).

Specifications

Grade II

Model	External dimensions [mm]			Internal dimensions [mm]			Weight	Capacity	Number of shelves
	H	W	D	H	W	D	[kg]	[litre]	pcs.
KP 45 ECB-S	450	580	570	290	420	330	180	40	1
KP 62 ECB-S	620	580	570	460	420	330	230	64	1
KP 85 ECB-S	850	580	570	690	420	330	270	96	1
KP 100 ECB-S	1000	580	570	840	420	330	310	116	2
KP 120 ECB-S	1200	580	570	1040	420	330	360	144	3
KP 150 ECB-S	1500	580	570	1340	420	330	430	186	4
KP 180 ECB-S	1800	580	570	1640	420	330	510	227	4

Grade III

Model	External dimensions [mm]			Internal dimensions [mm]			Weight	Capacity	Number of shelves
	H	W	D	H	W	D	[kg]	[litre]	pcs.
KP 62 ECB-S	620	580	570	460	420	330	310	64	1
KP 85 ECB-S	850	580	570	690	420	330	380	96	1
KP 100 ECB-S	1000	580	570	840	420	330	440	116	2
KP 120 ECB-S	1200	580	570	1040	420	330	460	144	3
KP 150 ECB-S	1500	580	570	1340	420	330	620	186	4
KP 180 ECB-S	1800	580	570	1640	420	330	730	227	4

Installation

Strong Safes are mounted to the floor using one steel expansion connector (Fig. 1).

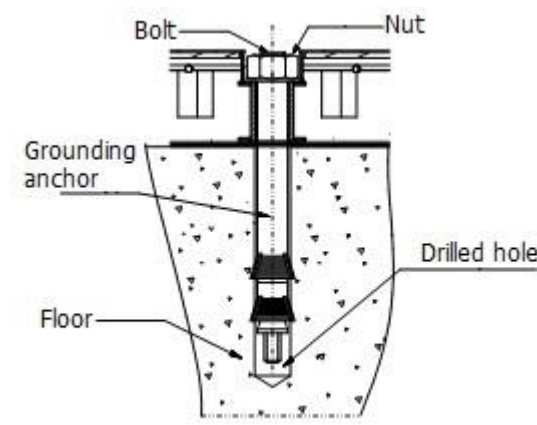

Fig. 1

NOTE: The steel expansion connector should be embedded in the floor at a depth of not less than 130 mm, in concrete of at least B15 class.

➤ **In order to anchor the Strong Safe to the floor, the following steps should be taken:**

1. Place the safe in the final location.
2. Remove the plug from the perforation in the Strong Safe bottom.
3. Drill a hole in the floor through the perforation in the device to the depth corresponding with the length of the expansion connector.
4. Place the Strong Safe so that the perforation in its bottom and the hole in the floor coincide.
5. Insert the anchor and fasten the nut. If the connector's bolt protrudes above the bottom of the Strong Safe interior after fastening the nut, loosen the nut, drill the bolt using a screwdriver and fasten the nut again.
6. Cover the perforation with a plug.

➤ **If the Strong Safe is too small to drill a hole in the floor through the perforation in its bottom (the drill does not fit into the Strong Safe, or for example when internal boxes are present), the following should be done:**

1. Measure the position of the perforation in the Strong Safe
2. Mark the location of the perforation on the floor.
3. Drill a hole in the floor to the depth corresponding with the length of the expansion connector.
4. Place the Strong Safe so that the perforation in its bottom and the hole in the floor coincide.
5. Insert the anchor and fasten the nut. If the connector's bolt protrudes above the bottom of the Strong Safe interior after fastening the nut, loosen the nut, drill the bolt using a screwdriver and fasten the nut again.
6. Cover the perforation with a plug.

KP Strong Safe, grade II-III with ECB-S certificate

Installation of separately lockable internal box

1. Open the Strong Safe.
2. Insert clips, on which the box will be supported, into the perforations on the interior body.
3. Insert the box to the Strong Safe
4. When the box is at the desired height, placed on the clips, drill holes in the wall of the interior body through the perforations in the rear wall of the box.
5. Rivet the box to the rear wall of the interior body through the prepared assembly openings.
6. Close the Strong Safe.

Installation of shelves

Safes are delivered with shelves packed separately and placed on the safe's bottom. After unwrapping the shelves, the shelf clips (in a bag) are located in the corresponding perforations in the battens (fig.2). Place the shelves on the clips. The location of the shelves depends on the needs of the user and can be adjusted.

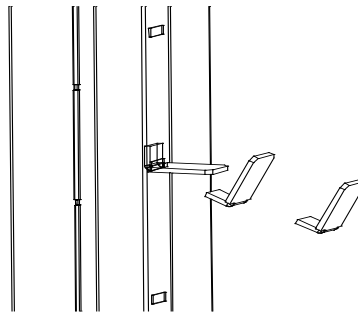

Fig. 2. Installation of shelf clips

Operation - opening

- **Opening of a safe fitted with a key lock only:**
 1. Insert the key into the lock hole.
 2. Turn the key by over 90° (over 1/4 of a turn) clockwise, resistance indicates that the lock is open, the key must remain in the lock (the key lock design prevents the key from being removed when the lock is in open position).
 3. Turn the handle clockwise.
 4. Pulling the door opens the safe.
- **Opening of safes fitted with combination or electronic lock:**
 1. Open the combination/ electronic lock following the steps described in the enclosed lock's operation manual.
 2. Turn the handle clockwise.
 3. Pulling the door opens the safe.
- **Opening of safes fitted with key and combination lock or electronic lock:**
 1. Insert the key into the lock hole.
 2. Turn the key by over 90° (over 1/4 of a turn) clockwise, resistance indicates that the lock is open, the key must remain in the lock (the key lock design prevents the key from being removed when the lock is in open position).
 3. Open the combination/ electronic lock following the steps described in the enclosed lock's operation manual.
 4. Turn the handle clockwise.
 5. Pulling the door opens the safe.

KP Strong Safe, grade II-III with ECB-S certificate

> **Opening of safes fitted with two key locks:**

1. Insert the key into the first lock hole.
2. Turn the key by over 90° (over 1/4 of a turn) clockwise, resistance indicates that the lock is open, the key must remain in the lock (the key lock design prevents the key from being removed when the lock is in open position).
3. Open the second lock proceeding as above.
4. Turn the handle clockwise.
5. Pulling the door opens the safe.

Operation - closing

> **Closing of a safe fitted with a key lock only:**

1. Close the door by pressing it against the body (door bolts must be concealed).
2. Turn the handle anti-clockwise.
3. Turn the key by over 90° (over 1/4 of a turn) anticlockwise, resistance indicates that the safe is locked.
4. Remove the key.

> **Closing of safes fitted with a combination or electronic lock only:**

1. Close the door by pressing it against the body (door bolts must be concealed).
2. Turn the handle anti-clockwise.
3. Close the combination/ electronic lock following the steps described in the enclosed lock's operation manual, the safe is closed.

> **Closing of safes fitted with key and combination lock or electronic lock:**

1. Close the door by pressing it against the body (door bolts must be concealed).
2. Turn the handle anti-clockwise.
3. Turn the key by over 90° (over 1/4 of a turn) anticlockwise, resistance indicates that the safe is locked.
4. Close the combination/ electronic lock following the steps described in the enclosed lock's operation manual, the safe is closed.

> **Closing of safes fitted with two key locks:**

1. Close the door by pressing it against the body (door bolts must be concealed).
2. Turn the handle anti-clockwise.
3. Turn the key by over 90° (over 1/4 of a turn) anticlockwise, resistance indicates that the safe is locked.
4. Close the second lock proceeding as above

Separately lockable internal box operation:

> **Box opening:**

1. Insert the key to the lock and turn it to the right by more than 90° (above 1/4 of a rotation).
2. Box is opened after pulling the door outwards.

> **Box closing:**

1. Push the door against the box body.
2. Rotate the key of any lock to the left by more than 90° (above 1/4 of a rotation). Resistance is proof of the lock blocking, remove the key, the device is locked.

KP Strong Safe, grade II-III with ECB-S certificate

Use

- Products should be used in rooms protected against weather conditions, away from substances that may cause metal corrosion. Relative humidity in the room should not exceed 75%. The device may work in rooms where temperature ranges from +5°C to +40°C.
- When closing or opening the safe, attention should be paid to movable elements: drawers, doors. When used inappropriately, these elements may cause injuries, e.g. finger injuries when fingers are left between the drawer and the body or between the door and the body of the safe.
- Attention should be paid to the location of the bolts during door closure. Bolts must be concealed to avoid damaging the mechanisms.
- No tinkering with the locks or mechanisms is allowed, under consequence of voiding the warranty.
- Only authorized service personnel or a user with a written approval of the service is allowed to install locks and mechanisms within the warranty period.
- If keys need to be changed, replacing the entire lock is recommended.
- Attention should be paid to the appropriate location of the safe, as to ensure uninterrupted opening of the safe's door.
- Bolting mechanisms and locks should work smoothly and without jamming. In the case of any reservations regarding the operation of these items, problems should be reported to KONSMETAL service.
- Any doubts concerning the delivered product should be reported to KONSMETAL service.
- No modifications without the approval of the manufacturer are recommended, even after the expiry of the warranty period.

Maintenance

➤ **Door:**

It is recommended to lubricate the hinges as necessary, however, no less frequently than once every three years using bearing grease. All the friction couplings and joints of mechanisms ought to be lubricated with technical acid-free petroleum jelly once every three years.

➤ **Body:**

In principle, the body does not require any special maintenance. Basic maintenance involves cleaning of the body housing. In order to do so, use a soft cloth dampened with mild detergent and then wipe the cleaned surface dry.

Replacement of the electronic lock's battery

Note:

Replacement of the battery does not require guarantee seals to be broken.

One 9V battery is required for the replacement.

Follow the instructions below in order to replace the battery.

The location of the battery depends on the type of installed lock. Most often battery is located on the internal side of the safe door (in a suitable battery container) or external part of the lock (lock keyboard).

1. If the battery is located in an external lock keyboard:
 - a. Open the safe.
 - b. Remove the black cover of the battery compartment located on the inside of the safe door.
 - c. Replace the battery noting the polarity - the markings "+" and "-".
 - d. **Check correct operation of the lock while the safe door is open** (open and extend bolts several times).
 - e. If the lock operates correctly, replace the battery compartment cover and close the safe.
2. If the battery is inside the safe (most often on internal side of the safe door):
 - a. Open the safe.

KP Strong Safe, grade II-III with ECB-S certificate

- b. Remove the black cover of the battery compartment located on the inside of the safe door.
 - c. Replace the battery noting the polarity - the markings "+" and "-".
 - d. **Check correct operation of the lock while the safe door is open** (open and extend bolts several times).
 - e. If the lock operates correctly, replace the battery compartment cover and close the safe.
3. If the battery is located on the internal side of the safe door and the lock cannot be opened, as well as the safe door are closed:
- a. Check whether the lock keypad has special contact pins to applicate additional battery and emergency lock opening.
 - b. Replace the battery noting the polarity - the markings "+" and "-".
 - c. Hold the whole time additional battery with the contact pins, open the lock with normal code and then unlock the safe door.
 - d. After unlocking the safe door additional battery can be detached and the old battery can be replaced as described above.

Warning: Make sure that the ends of the battery with positive and negative polarity are matched correctly, as marked in the battery compartment. If the battery is installed incorrectly, running the lock will not be possible.

There are locks supplied more than one battery, in such cases, replace all the batteries at the same time. Do not mix old and new batteries or mix batteries of different types (for example, alkaline and lithium batteries). Batteries should not be opened, punctured, loaded, installed, or exposed to fire, heat or water. It is recommended to only use alkaline or lithium batteries of known brands.

Adjustment of hinges

KP Strong Safes have external hinges.

To make an adjustment you need two hex keys of size 4mm.

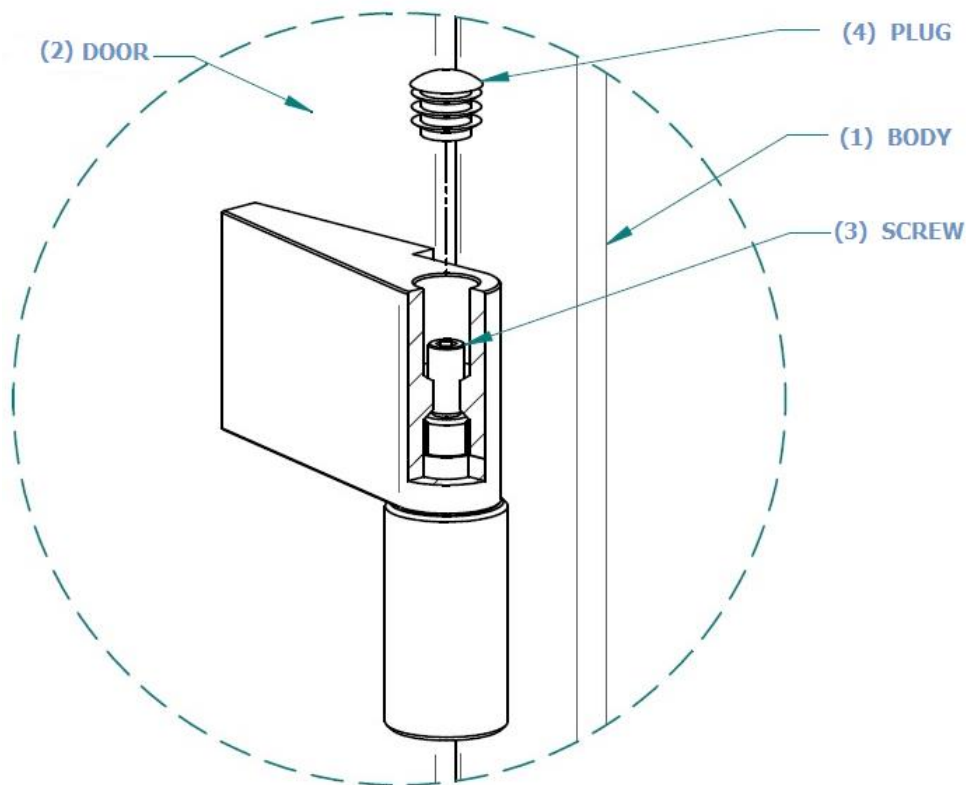

Fig. 3 Upper hinge

KP Strong Safe, grade II-III with ECB-S certificate

> Adjustment of hinges is performed as follows:

1. Remove the plug (4) from the upper hinge.
2. Height adjustment of the door (2) is done by using the adjustment screw (3) by turning the hex key 4mm. Lifting of the door is done by turning the screw clockwise. Lowering of the door is done by turning the screw (3) in the opposite direction.
3. Use glue to secure the thread from the unscrewing the screw (3). Before adjusting unscrew the adjustment screw (3) and apply onto the thread a few drops of thread glue (permanent joints)
4. Insert the plug into the hinge hole (4).

Adjustments is performed so that the slots on the top and bottom of the door were equal (control on half closed door of the safe). In case of problems, please contact the Service.

Most common problems and remedies

- 1. Key or combination lock does not close:**
 - a. Make sure bolts blocking the door opening are extended. If after their maximum ejection lock does not close, please contact the Service.
- 2. Combination lock cannot be opened despite selecting the correct code:**
 - a. Make sure the other person has not changed the code.
 - b. Make sure that the base of the lock knob with the code set marker does not come loose and the marker is not moved aside from its original position – if so, try to set code in different positions of the marker and then contact the Service to improve the fixing base.
- 3. Electronic lock works differently than usual – sounds are different and/or diode blinks:**
 - a. Check the manual of the lock whether lock signals low battery – if so, replace the battery immediately with a new one according to the lock manual.
 - b. Make sure that it is not related to entering the wrong code. Detailed information on the unusual situation signaling by the relevant model of the lock can be found in the lock manual.
WARNING! Triple attempt of entering the wrong code moves the lock into 'punishment' mode which means that the lock will not accept any code for a certain time. To open the lock you must wait for a certain time defined for that lock and then enter the correct code. Details are given in the lock manual.
- 4. Electronic lock makes no sound or does not open:**
 - a. Replace the battery or connect a new battery with the emergency power supply contact pins (depending on the model of the lock – see the lock manual) and then try to open the lock. If the lock still does not open please contact the Service.

Contact details to the KONSMETAL Service

phone: **+48 89 625 37 99** (Monday – Friday: 8-16)

e-mail: **serwis@konsmetal.pl**

When contacting the Service keep prepared the following data (if possible):

- Device model
- Purchase date
- Serial number (from the nameplate located inside the device)

In order to verify whether the product is under warranty in most cases it is sufficient to give the serial number from the nameplate. Sometimes you will need proof of purchase or warranty card with purchase date and vendor's stamp.